

VLAZE

MODULAR FURNITURE FOR
INDOOR & OUTDOOR LIVING





VLAZE

MODULAR FURNITURE FOR
INDOOR & OUTDOOR LIVING

VLAZE ADAPT is an innovative collection of modular and freestanding furniture that can be moved freely from indoors to outside.

Designed for outdoor living these pieces offer the perfect solution for food preparation and al fresco dining.

The kitchen modules are engineered from stainless steel and adorned with a vitreous enamel surface while the dining tables and planters use a combination of aluminium, steel and vitreous enamel. This durable, weather proof enamel finish is created by fusing powdered glass to steel at temperatures in excess of 800°C. The result is a luxurious vibrant glaze that is heatproof, hygienic and stain resistant and is guaranteed for 25 years.

VLAZE is British made on the Isle of Wight by the makers of the iconic signage for the London Underground and the Paris Metro.



VLAZE THE INSIDE OUT KITCHEN

An open plan kitchen that utilises the free moving ADAPT ISLAND and ADAPT 120 to connect the inside with the outside. The inside element of this kitchen features a fixed ADAPT 240 unit with integrated sink and electric oven while the two movable units can be used indoors or out making for a beautifully versatile space.

ADAPT 120 C in Quilted Graphite
ADAPT SPLASHBACK in Nori
SINK 240 L in Quilted Graphite with bamboo worktop
ADAPT ISLAND in Indigo Stipple





VLAZE THE KITCHEN TERRACE

The combination of an ADAPT 120 with an ADAPT KOMADO 120 creates an instant, outdoor kitchen for food preparation, cooking and entertaining.



ADAPT 120 C in Black Splatter
KOMADO 120 C in Quilted Graphite
featuring Big Green Egg



VLAZE THE GARDEN PAVILLION

The ADAPT 120 incorporated into this outdoor living room by 2LG Studio. This versatile unit can serve as a cocktail cabinet or food preparation area creating a striking focal point for this outdoor summer pavillion.

ADAPT 120 C in Indigo Stipple
Bespoke table top in matching Indigo Stipple



©Megan Taylor





VLAZE POOLSIDE DINING

The ADAPT DINING TABLE in Nori paired with matching low planters by this natural poolside. The table comfortably seats up to eight people, features a durable vitreous enamel top with aluminium base and is fully weather proof. The movable planters provide a striking yet practical solution for plants and foliage that can be reconfigured to divide outdoor living areas.

ADAPT DINING TABLE in Nori

ADAPT LOW PLANTERS in Black Splatter, Quilted Graphite, Indigo Stipple and Nori



*Appliances not included. All dimensions in mm.

ADAPT CORNER PLANTER L
700 x 700 x 900
Leg base

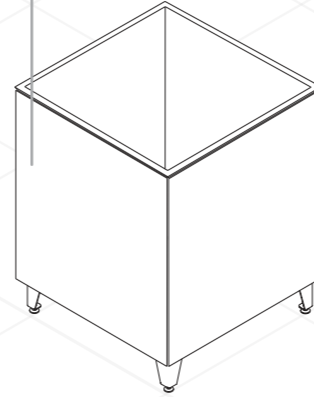

ADAPT SINK 240 L
2400 x 700 x 900
Leg base
including Caple Sink & Tap

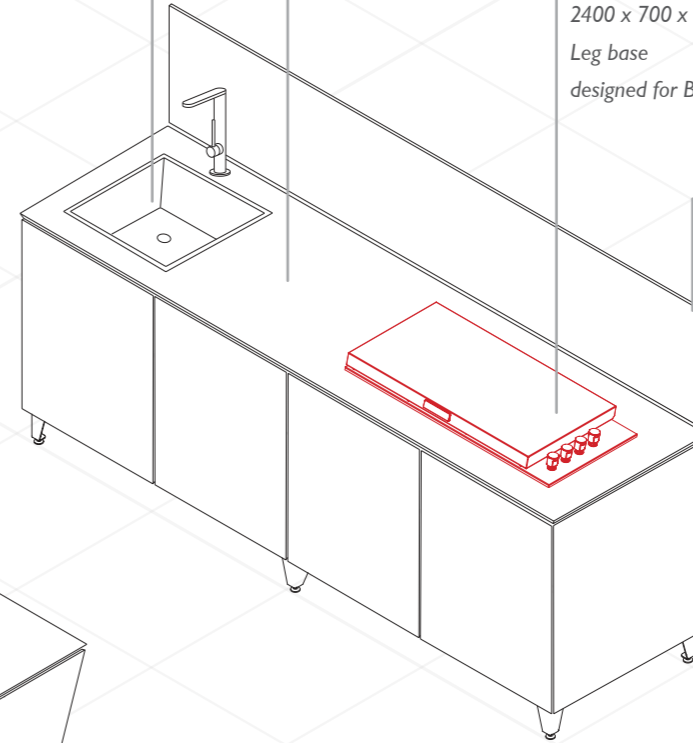

ADAPT 240 L
2400 x 700 x 900
Leg base

ADAPT GRILL 240 L
2400 x 700 x 900
Leg base
designed for Beefeater Signature Proline*

ADAPT SPLASHBACK
2400 x 500 x 12

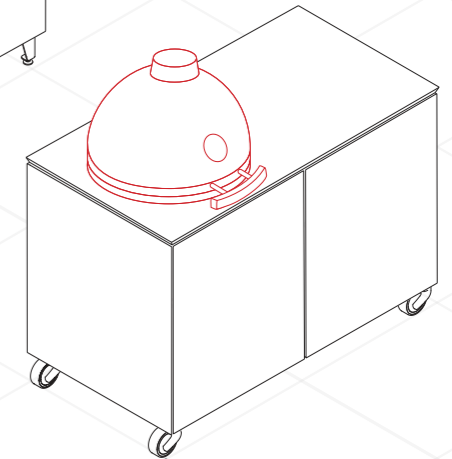

ADAPT SPLASHBACK
1200 x 500 x 12

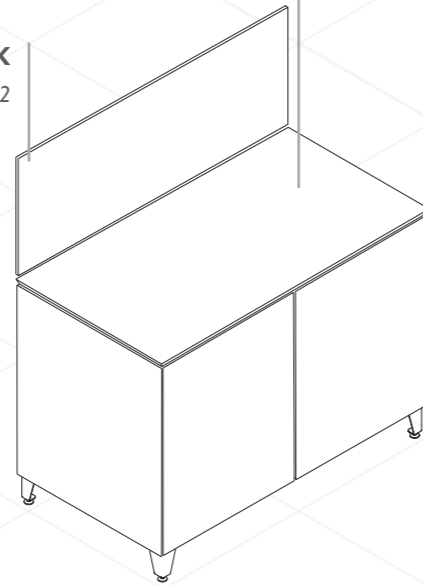

ADAPT 120 L
1200 x 700 x 900
Leg base

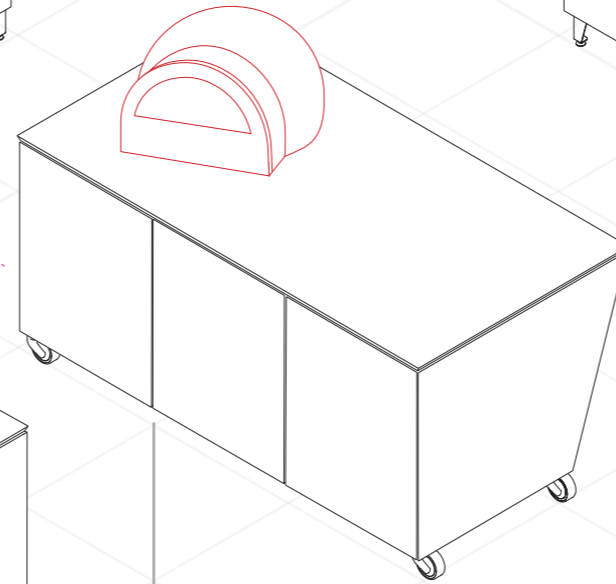

ADAPT LOW PLANTER C
600 x 600 x 600
Castor base

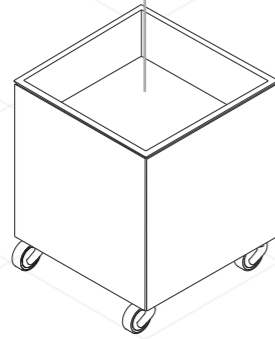

ADAPT GRILL 120 L
1200 x 700 x 900
Leg base
designed for Beefeater Signature Proline*

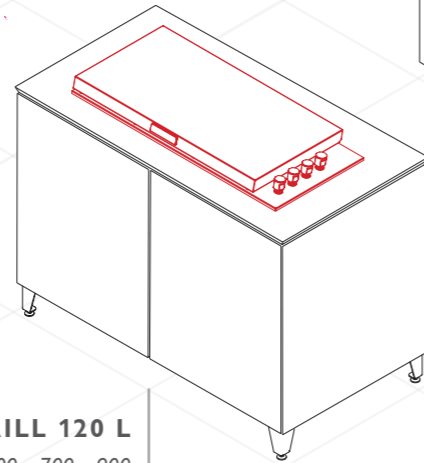

ADAPT ISLAND
1800 x 950 x 900
Castor base
featuring DeliVita Pizza Oven*



ADAPT DINING TABLE
2000 x 950 x 750

ADAPT KOMADO 120 C
1200 x 700 x 900
Castor base
designed for Big Green Egg*

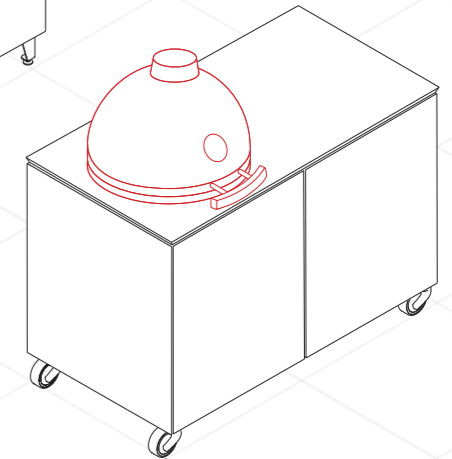

VLAZE

THE VLAZE ADAPT COLLECTION

Modular outdoor furniture that that is fully configurable to suit every outdoor living space from balconies and courtyards to terraces and pavillions.



VLAZE THE KITCHEN GARDEN

The ADAPT ISLAND used as the perfect pizza station in this bright kitchen garden terrace. The heat proof finish allows the pizza oven to be placed directly on the unit. The addition of a matching ADAPT 120 provides additional food and drink preparation. When not cooking outside the units can be repurposed for use indoors.



ADAPT 120 C in Indigo Stipple
ADAPT ISLAND in Indigo Stipple
featuring DeliVita Pizza Oven





VLAZE THE LONDON COURTYARD

In this compact urban courtyard the ADAPT KOMADO 120 provides a space saving area dedicated to food preparation and cooking plus ample storage for kitchen equipment, utensils and fuel.

KOMADO 120 C in Quilted Graphite featuring Big Green Egg



VLAZE THE MODULAR KITCHEN

The ADAPT 120 is used as an additional preparation and storage space for this kitchen area. The castors allow it be moved and reconfigured around the space.

ADAPT 120 C in Black Splatter





VLAZE THE FARMHOUSE KITCHEN

These two ADAPT 120 units inject a splash of colour into this sunny courtyard forming a versatile entertaining area for food and drink preparation. The heat proof finish allows the pizza oven to be placed directly onto the unit.



ADAPT 120 C in Ochre featuring a Morso Forno Pizza Oven
ADAPT 120 C in Nori



THE VLAZE ADAPT COLLECTION

ADAPT 120

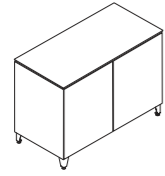

1200 x 700 x 900
Vitreous enamel / stainless steel body.
5 colour options
3 worktop options
2 base options

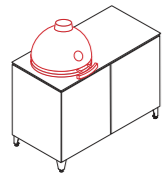

KOMADO 120
Unit designed to house large Big Green Egg*

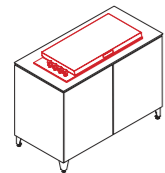

GRILL 120
Unit designed to house Beefeater Signature Proline gas grill*

ADAPT ISLAND

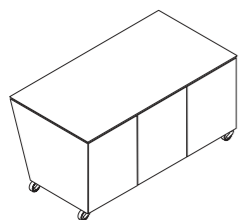

1800 x 950 x 900
Vitreous enamel / stainless steel body.
5 colour options
2 worktop options
Castor base only

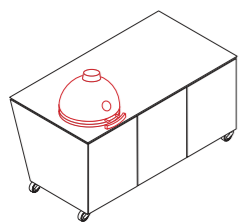

KOMADO ISLAND
Unit designed to house large Big Green Egg*

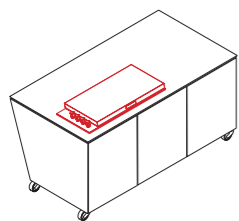

GRILL ISLAND
Unit designed to house Beefeater Signature Proline gas grill*

ADAPT 240

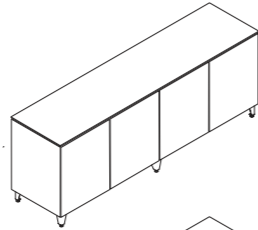

2400 x 700 x 900
Vitreous enamel / stainless steel body.
5 colour options
3 worktop options
2 base options

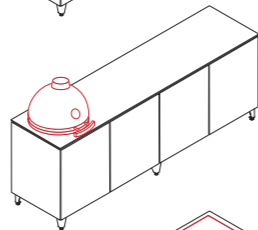

KOMADO 240
Unit designed to house large Big Green Egg*

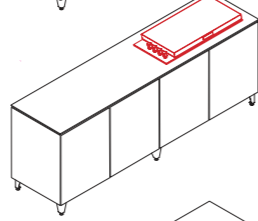

GRILL 240
Unit designed to house Beefeater Signature Proline gas grill*

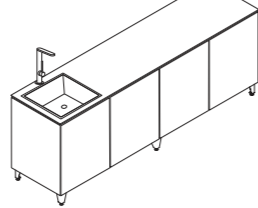

SINK 240
Unit includes Caple Mode045 sink and Kar tap in Gunmetal

ADAPT DINING TABLE

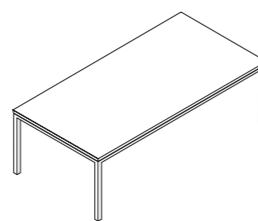

2000 x 950 x 750
Vitreous enamel / Aluminium base
5 colour options

ADAPT PLANTER

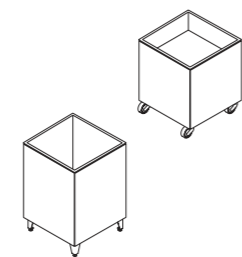

LOW 600 x 600 x 600
CORNER 700 x 700 x 900
Vitreous enamel / galvanised steel body.
Drop-in tray options
5 colour options
2 base options

OPTIONS



ADAPT SPLASHBACKS

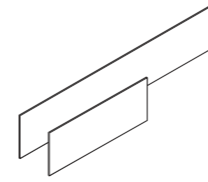

Wall mounted
Vitreous enamel
2400 x 500 x 12
1200 x 500 x 12

ADAPT WORKTOP

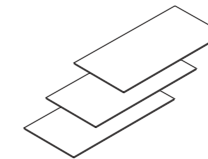

Vitreous Enamel
Stainless Steel
Bamboo (indoor use only)

ADAPT BASE OPTIONS



Castors (C)
Legs (L)

ADAPT ALL WEATHER COVER

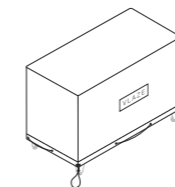

Breathable all weather cover in mid grey. Available for all ADAPT furniture.

ADAPT COLOUR



Quilted Graphite



Black Splatter



Indigo Stipple



Ochre



Nori

Please note: All colours have been reproduced as faithfully as print will allow. Photos should not be taken as an exact indication of colour.

ENAMEL FINISH: VLAZE enamels are milled in-house using natural compounds and oxides therefore batches may differ slightly in colour and finish. This is part of the unique, organic character of vitreous enamel. All dimensions in mm.

*Appliances not included.



25
YEAR GUARANTEE



VLAZE BISHOPS WAY, NEWPORT, ISLE OF WIGHT PO30 5WS, UK
TEL: +44 (0)1983 537 773 • **VLAZE.CO** • @VLAZESURFACE

A DIVISION OF A.J.WELLS & SONS LIMITED REGISTERED IN ENGLAND NO. 03809371 • AJWELLS.COM 